

NOZZLE CHART	
NOZZLE ID	NPT SIZE
N1	1/4
N2	1/2
N3	1 1/2

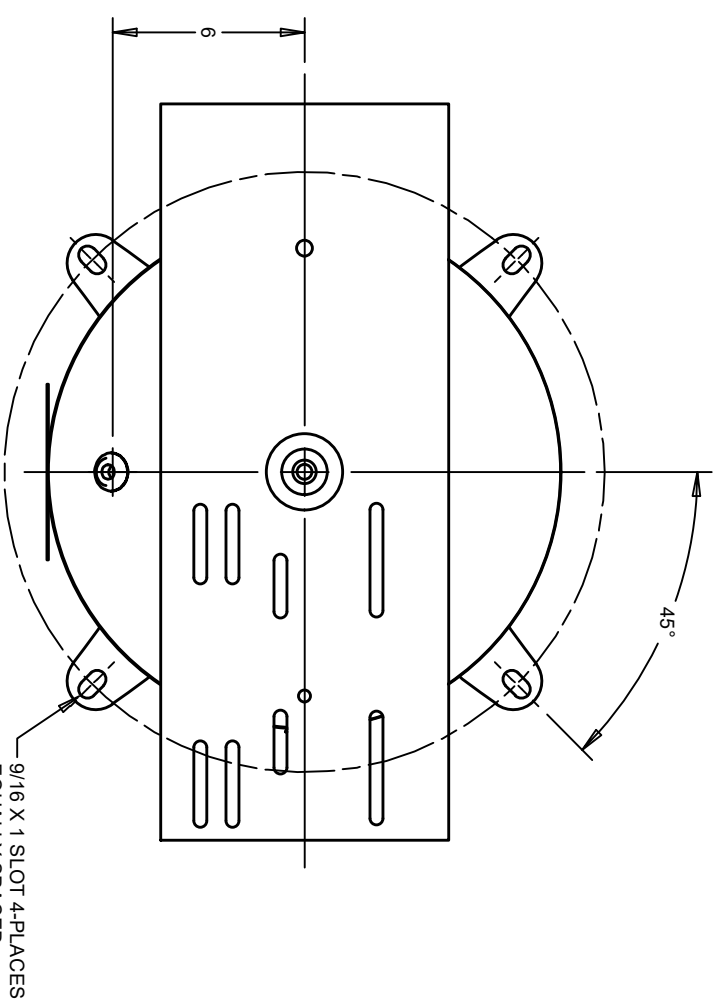

TOP VIEW

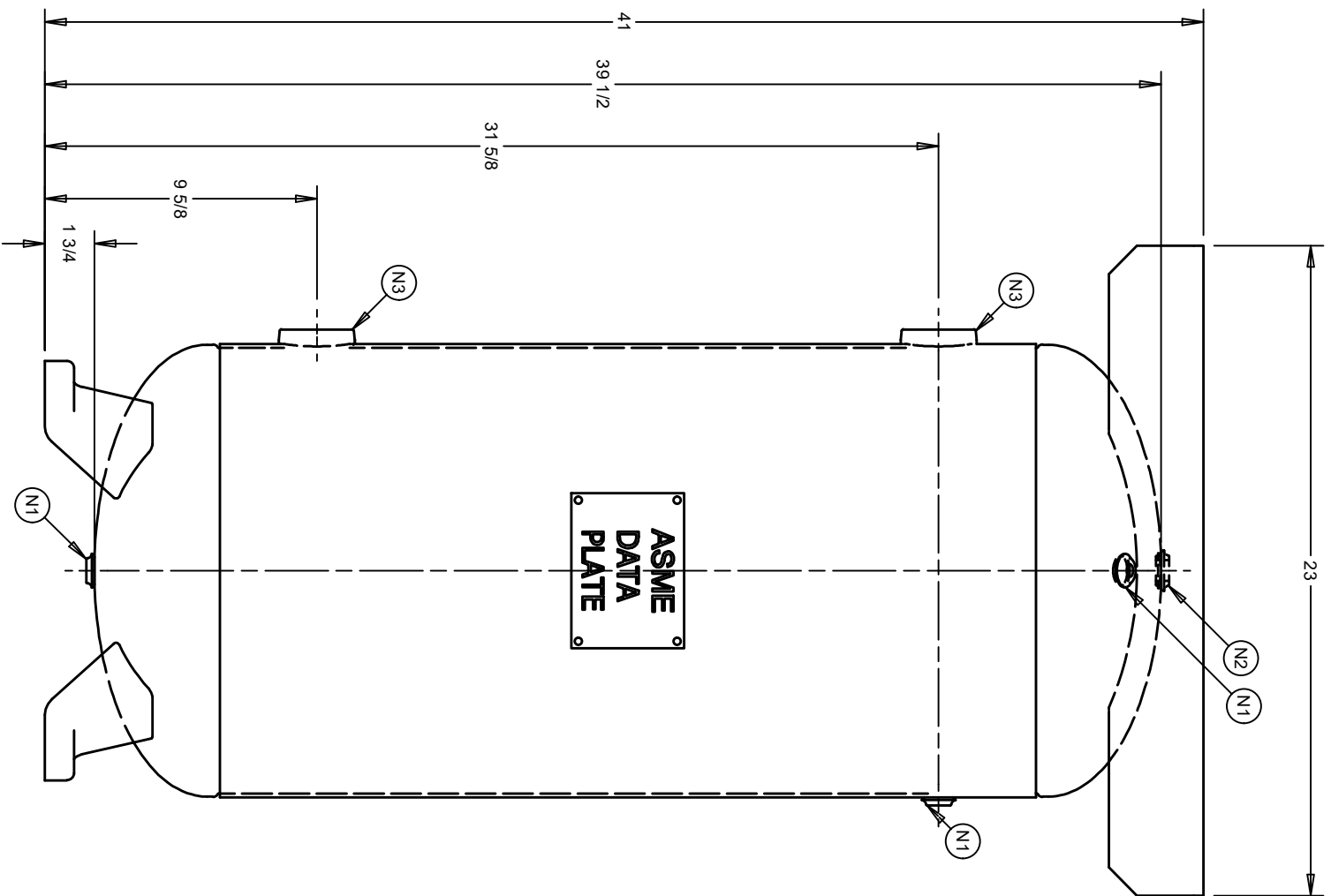
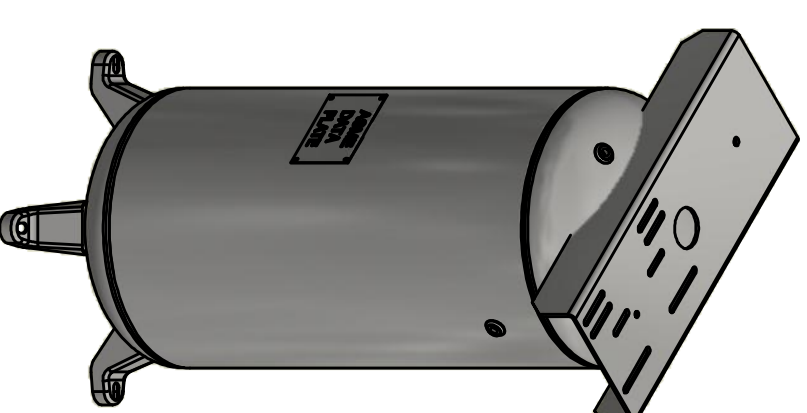

DESIGN INFORMATION		VALUE
SPECIFICATION		16 O.D.
DIAMETER O.D./I.D.		200 PSI AT 400°F
MAWP		-20°F AT 200 PSI
MDMT		APPROX 30 GALLONS
CAPACITY		101 LBS
SHIPPING WEIGHT		L4032.5C
CRN		

TITLE
VERTICAL AIR RECEIVER



CUSTOMER	DRAWN	CHECKED	DRAWING NO	REV
STOCK	KAT	DMM	A10041	B16
	9/1/2016	9/19/2016		

REV	DESCRIPTION	BY	DATE
B16	ISSUED		

(BUILT IN ACCORDANCE WITH LATEST EDITION OF SECTION VIII DIV 1 ASME CODE)
THIS DRAWING & SPECIFICATIONS ARE PROPERTY OF SPVG AND MAY NOT BE COPIED, REPRODUCED, OR USED IN WHOLE OR PART, AS A BASIS FOR DESIGN MANUFACTURE OR SALE WITHOUT PRIOR PERMISSION FROM SPVG.