

SHELL CAN BE MADE FROM ONE COURSE OR 2 COURSES  
 SHOP ORDER MUST BE ADJUSTED ACCORDINGLY.

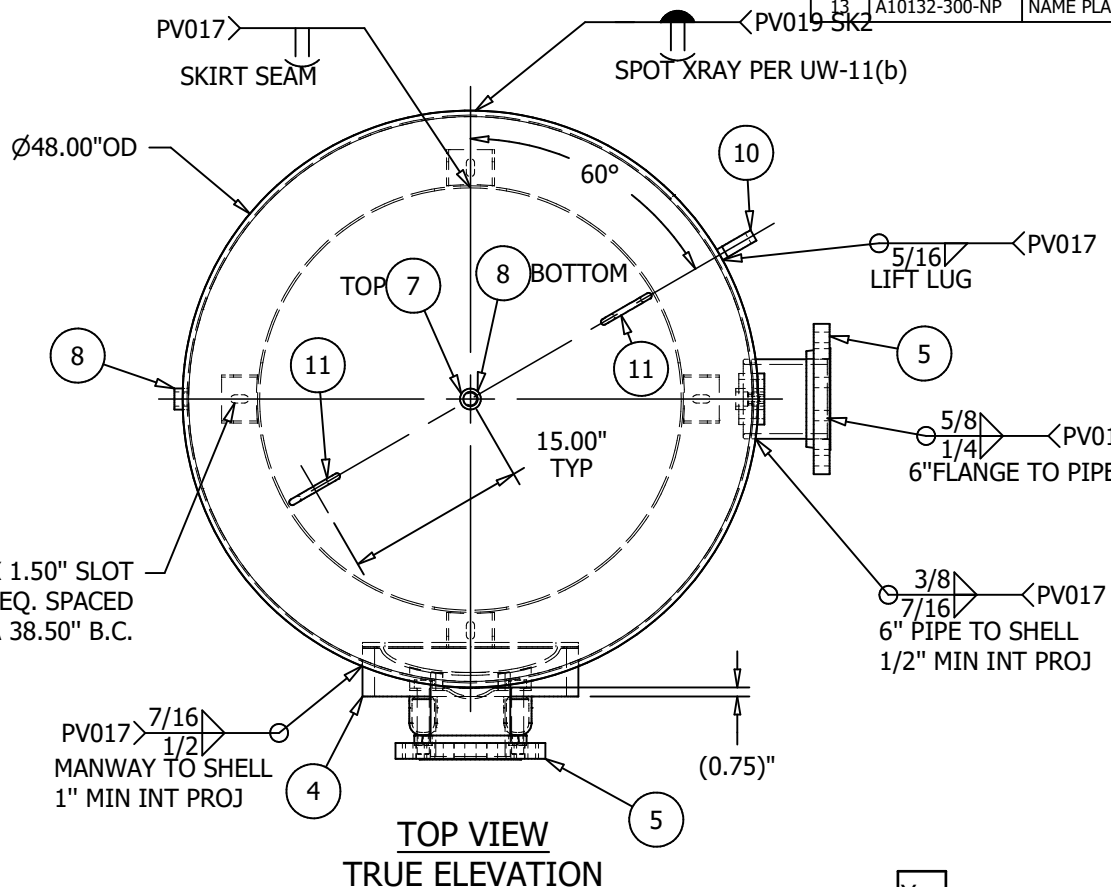
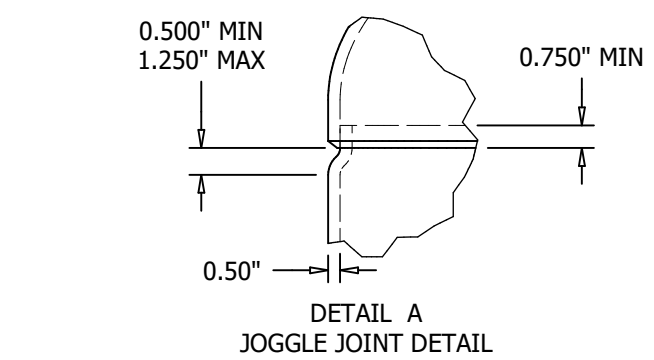
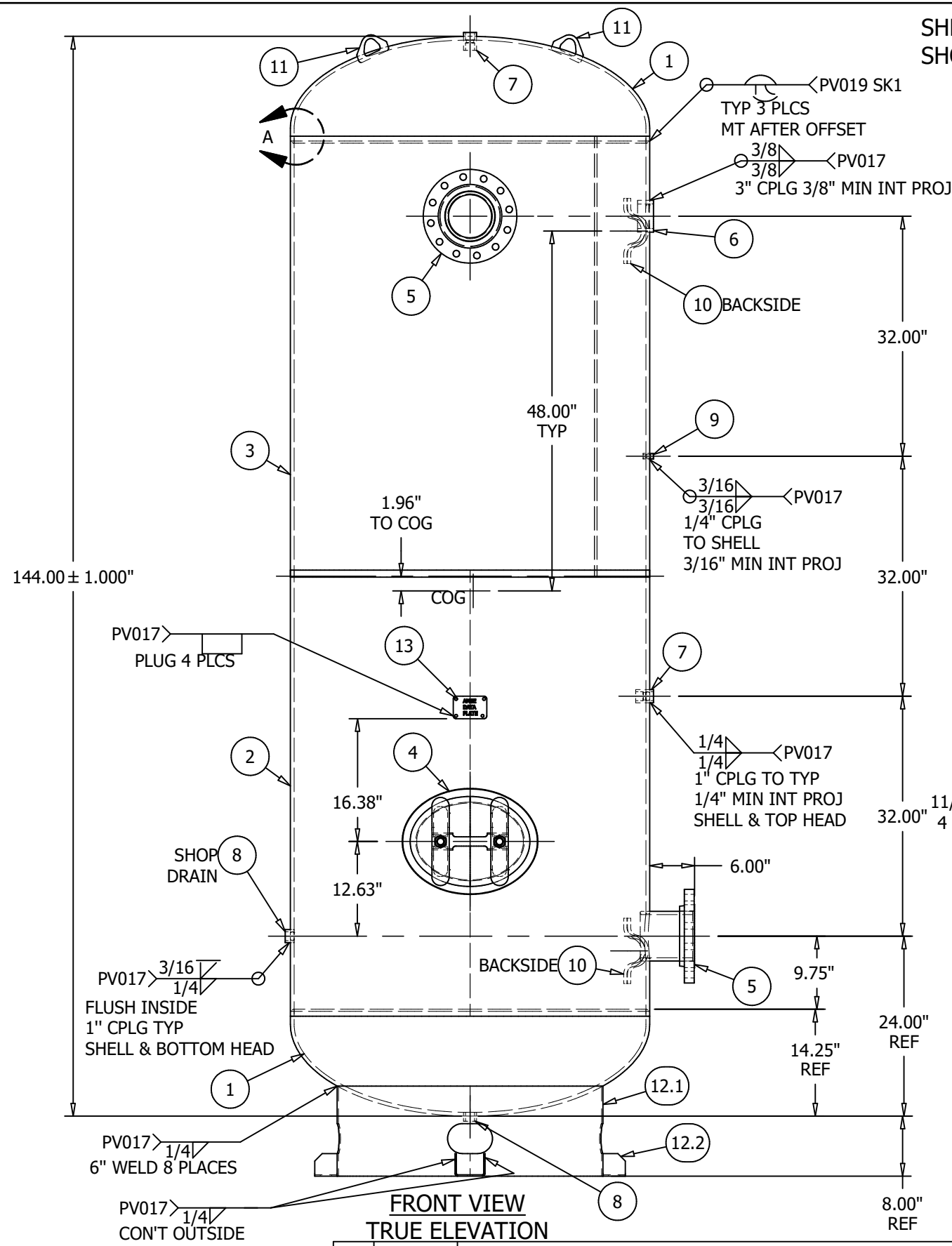

ITEM	P/N	DESCRIPTION	QTY
1	H48500P	HEAD 48.00 OD 0.438M/0.500N SA516-70 SE 2:1 PLAIN W/2" SF BEVELED	2
2	A10132-300-SL1	SHELL BURNT 0.500 CS SA516-70 59.50 X 48.00 OD	1
3	A10132-300-SL2	SHELL BURNT 0.500 CS SA516-70 58.81 X 48.00 OD	1
4	S100343-S	MANWAY 12.00 X 16.00 X 4.000 X 1.00 RNG SA106C C/W 300# CLOSURE	1
5	S114911	RFSo ASY 6.000 300# S80 (0.432 WALL) 7.250 LG SA105 ANSI B16.5/ SA106-B	2
6	F603000H	CPLG 3.000 NPT SA105 ANSI B16.11 3000# HALF	1
7	F601000	CPLG 1.000 NPT SA105 ANSI B16.11 3000# FULL	2
8	F601000H	CPLG 1.000 NPT SA105 ANSI B16.11 3000# HALF	2
9	F600250	CPLG 0.250 NPT SA105 ANSI B16.11 3000# FULL	1
10	64-784-H	LIFT LUG 0.500 A36 3.25 X 8.71 FOR 36-72" TANKS	2
11	S101972	LIFT LUG 0.500 SA105 3.000 X 4.875 PHOENIX 2-900-LUG (6800#)	2
12	S102114	SKIRT ASY 7GA A1011CS-B X 35.50 OD W/8.000 CLR, 38.50 BC FOR 42 & 48 TANKS	1
12.1	S100066	SKIRT 7GA A1011CS-B 12.000 X 35.50 OD W/8.000 CLR	1
12.2	S102021	SKIRT CLIP 7GA A1011CS-B 3.000 X 4.000 X 3.000 LG W/.688"x1.5" SLOT FOR 42"-60" TANKS	4
13	A10132-300-NP	NAME PLATE FOR A10132-300 A1011CS-B	1

\*\*SHELL CUT SIZE IS REFERENCE ONLY  
 \*\*CPLG & FITTING 0.50 EXT PROJ TYP  
 \*\*HEAD THICKNESS SHOWN IS SPECIFIED MINIMUM  
 \*\*RADIUS INSIDE PROJECTED EDGES OF NOZZLES 1/8" MIN  
 \*\*SEE PAGE 2 FOR FINISH  
 \*\*FLANGE BOLT HOLES STRADDLE TANK C/L EXCEPT AS NOTED  
 \*\*ALL DIMS IN INCHES UNLESS NOTED OTHERWISE  
 \*\*IMPACT TEST EXEMPT PER UG 20(f) & UCS-66  
 \*\*MANWAY CRN: OH7098.5C  
 \*\*FITTING CRN: OH0693.9C  
 \*\*RADIGRAPHY: RT4  
 48" X 144" 300# VERTICAL AIR RECEIVER  
 NOTES

TRAVELER REQUIRED  Yes      FIXTURE REQUIRED  No      IF YES THEN FIXTURE # ---

RELEASED TO PRODUCTION		TOLERANCES ARE PER EN1370 STEEL FAB STANDARD TOLERANCES UNLESS OTHERWISE SPECIFIED		DESIGN & CALCULATIONS COMPLY WITH ASME CODE SECTION VIII, DIV.1 2017 EDITION	
SALES ORDER#		QTY:		SPVG STOCK	
RELEASE DATE:		NAT'L BD: YES		ENG. APP'L / DATE MH - 12/6/2014	
NB/SERIAL#		STAMP " U "		QCM. APP'L / DATE JP-12/15/2014	
HEAD THK: .438" MIN C.A.: --- MAT'L SA516-70 EFF 85 %		VOLUME: 1060 APPROX GAL		A.I. VERIFICATION / DATE BQ-12/15/2014	
SHELL THK: .500" NOM C.A.: --- MAT'L SA516-70 EFF 85 %		MAMP 300 PSI AT 400 °F		SAMUEL PRESSURE VESSEL GROUP	
SHIPPING WEIGHT: 3580 LBS		MDMT -20 °F AT 300 PSI		OAKVILLE, ONT      LEBANON, VA	
CRN: A8570.3		TEST: HYDRO AT 390 PSI		DRAWN BY: IDV      P/N A10132-300	
		TEST: PNEU AT --- PSI		DATE: 11/12/2014	

REV	DATE	DESCRIPTION	ENG	QCM	AI/DATE
5	8/3/21	ADDED JOINT DETAIL SKETCH	RM	N/A	BQ 8/3/21
6	9/2/22	6" RFSo ASY WAS S105494	MG	N/A	BQ 9/7/22