

# Compressed Air Coalescing Filters

Models | A30006 to A31500

Flow Rates 6 SCFM (10 Nm<sup>3</sup>/hr) to 1500 SCFM (2550 Nm<sup>3</sup>/hr)

**Introducing the Alpha, Walker Filtration's latest range of market leading compressed air and gas filters. With enhanced housing features and a step change in element performance, the Alpha delivers a high quality filtration solution you can trust.**

Offered in a range of 18 models with connection sizes ranging from 1/8" to 3", the Alpha Series has been tested to provide a saturated differential pressure of <1.8 psi (125 mbar) across X1 and XA grades - proving to be our most advanced filter to date.

With class leading performance and exceptional results in oil aerosol and particle retention, Alpha Compressed Air Filters deliver significantly reduced pressure loss and optimum filtration efficiencies - to ensure continually low operational costs.

Market leading differential pressure of <1.8 psi across X1 and XA grades



**Modular Filter**

Low cost connecting kits and new filter head design enables easy close coupling assembly



**Filtration Technology**

Alpha deep pleated media technology delivers a step change in performance



**Externally Accessible Drain**

Eliminates the need to access the inside of the filter housing when servicing the drain



- **Flow-Optimized Design** Advanced filter head design for optimized flow performance
- **Flexible Installation** Modular design and accessible fixings enable simple close coupling assembly
- **Market Leading Performance** Custom engineered filtration media delivers optimum performance in line with air quality standard ISO 8573-1: 2010
- **Simplified Serviceability** Externally accessible drain, profiled bowl design and unique push fit elements ensure quick and reliable maintenance
- **Corrosion Protection** Internal and external electrophoretic paint finish followed by a tough exterior polyester powder coating
- **Color Coded Element End Caps** Easy and accurate grade identification
- **Product Safety in Mind** Guaranteed safe housing closure with rotational safety stop



# Technical Specification

Filter model	Pipe size inches	Inlet flow rate*		Dimensions inches (mm)				Weight		Element model
		SCFM	Nm <sup>3</sup> /hr	A	B	C	D	lbs	kg	
A30006 (grade)	1/8	6	10	1.97 (50)	0.67 (17)	6.18 (157)	2.36 (60)	0.7	0.3	E30306 (grade)
A30015 (grade)	1/4	15	25	1.97 (50)	0.67 (17)	6.18 (157)	2.36 (60)	0.7	0.3	E30306 (grade)
A30025 (grade)	1/4	25	42	2.76 (70)	0.91 (23)	7.44 (189)	2.76 (70)	1.1	0.5	E30408 (grade)
A30032 (grade)	3/8	32	54	2.76 (70)	0.91 (23)	7.44 (189)	2.76 (70)	1.1	0.5	E30408 (grade)
A30050 (grade)	1/2	50	85	2.76 (70)	0.91 (23)	9.09 (231)	2.76 (70)	1.3	0.6	E30412 (grade)
A30070 (grade)	1/2	70	119	5.00 (127)	1.26 (32)	11.22 (285)	3.15 (80)	3.7	1.7	E30612 (grade)
A30085 (grade)	3/4	85	144	5.00 (127)	1.26 (32)	11.22 (285)	3.15 (80)	3.7	1.7	E30612 (grade)
A30105 (grade)	1	105	178	5.00 (127)	1.26 (32)	11.22 (285)	3.15 (80)	3.7	1.7	E30612 (grade)
A30125 (grade)	3/4	125	212	5.00 (127)	1.26 (32)	14.57 (370)	3.15 (80)	4.4	2.0	E30621 (grade)
A30175 (grade)	1	175	297	5.00 (127)	1.26 (32)	14.57 (370)	3.15 (80)	4.4	2.0	E30621 (grade)
A30280 (grade)	1 1/4	280	476	5.51 (140)	1.61 (41)	18.74 (476)	3.35 (85)	6.6	3.0	E30731 (grade)
A30320 (grade)	1 1/2	320	544	5.51 (140)	1.61 (41)	18.74 (476)	3.35 (85)	6.6	3.0	E30731 (grade)
A30400 (grade)	1 1/2	400	680	6.69 (170)	2.08 (53)	20.00 (508)	3.94 (100)	10.8	4.9	E30831 (grade)
A30450 (grade)	2	450	765	6.69 (170)	2.08 (53)	20.00 (508)	3.94 (100)	10.8	4.9	E30831 (grade)
A30700 (grade)	2	700	1189	6.69 (170)	2.08 (53)	27.87 (708)	3.94 (100)	12.1	5.5	E30850 (grade)
A30850 (grade)	2 1/2	850	1444	8.66 (220)	2.75 (70)	28.97 (736)	3.94 (100)	23.1	10.5	E31140 (grade)
A30900 (grade)	3	900	1529	8.66 (220)	2.75 (70)	28.97 (736)	3.94 (100)	23.1	10.5	E31140 (grade)
A31250 (grade)	3	1250	2125	8.66 (220)	2.75 (70)	33.74 (857)	3.94 (100)	25.4	11.5	E31160 (grade)
A31500 (grade)	3	1500	2550	8.66 (220)	2.75 (70)	39.56 (1005)	3.94 (100)	27.6	12.5	E31175 (grade)

\*Rated flow at 100 psig (7 barg), reference conditions at 14.5 psi (a) (1 bar (a)) 35°F (20°C)

Grade	X5		X1		XA		AC	
Particle removal	5 micron		1 micron		0.01 micron		0.01 micron	
Maximum particle size class**	4		3		1		1	
Maximum oil content**	4		3		1		1	
Maximum oil carryover at 68°F (20°C)	5 ppm	5 mg/m <sup>3</sup>	0.3 ppm	0.3 mg/m <sup>3</sup>	0.01ppm	0.01 mg/m <sup>3</sup>	0.003 ppm	0.003 mg/ m <sup>3</sup>
Pressure loss - clean & dry	0.6 psi	40 mbar	0.8 psi	55 mbar	1.2 psi	85 mbar	1.7 psi	115 mbar
Pressure loss - saturated	1.1 psi	75 mbar	1.8 psi	125 mbar	1.8 psi	125 mbar	N/A	N/A
Pressure loss - element change	12 mths	8000 hrs	8000 hrs	12 mths	8000 hrs	12 mths	at least every 6 mths	
Maximum temperature - automatic drain	176°F	80°C	176°F	80°C	176°F	80°C	122°F***	50°C***
Maximum working pressure - automatic drain	232 psig	16 barg	232 psig	16 barg	232 psig	16 barg	232 psig	16 barg
Maximum temperature - manual drain	248°F	120°C	248°F	120°C	248°F	120°C	122°F***	50°C***
Maximum working pressure - manual drain	300 psig	20.7 barg	300 psig	20.7 barg	300 psig	20.7 barg	300 psig	20.7 barg
Element end cap colour	Green		Red		Blue		Black	

\*\* to ISO 8573-1: 2010 \*\*\* Maximum recommended operating temperature 77°F (25°C)

Pressure correction factors	For maximum flow rate, multiply model flow rate by the correction factor corresponding to the minimum operating pressure									
Operating pressure psig (barg)	58 (4)	72 (5)	87 (6)	100 (7)	115 (8)	145 (10)	174 (12)	203 (14)	232 (16)	300 (20.7)
100 psig - correction factor	0.76	0.84	0.92	1.00	1.07	1.19	1.31	1.41	1.51	1.73

## Technical notes

- Direction of air flow is inside to out through the filter element.
- Pop up indicators (65DPUG3) are fitted to models A30025 to A30050 as standard. Differential pressure indicators (65DPIG) are fitted to models A30070 to A31500 as standard. Activated Carbon (AC) grade filters do not include DP equipment. Volt free contact options are available upon request - see price guide.
- Coalescing Filters are fitted as standard with normally open float operated automatic drain valves, ADVS16 on models A30006 to A30050 and ADVSE16 on models A30070 to A31500, and manual drain valves on Activated Carbon Filters. Standard filters can operate at 232 psig (16 barg) at 176°F (80°C). Normally closed operated automatic drain valves (ADVSE16C) are available for low range flow applications (2.5 SCFM, 4.2 Nm<sup>3</sup>/hr or lower). 300 psig (20.7 barg) range at 248°F (120°C) available when supplied with a manual drain valve (MDV25 on models A30006 to A30050 and MDVE25 on models A30070 to A31500).
- Activated Carbon Filters must not operate in oil saturated conditions and will not remove certain types of gases including carbon monoxide (CO) and carbon dioxide (CO<sub>2</sub>).
- Alpha Filters are manufactured from cast aluminum alloy and are PED 2014/68/EU compliant for group 2 gases.
- Standard threaded connections are NPT to ANSI/ASME B1.20.1. RP (BSP Parallel) to ISO 7-1 and RC (BSP Taper) to ISO 7-1 are also available upon request.
- Filters are suitable for use with mineral and synthetic oils plus, oil-free compressed air applications.

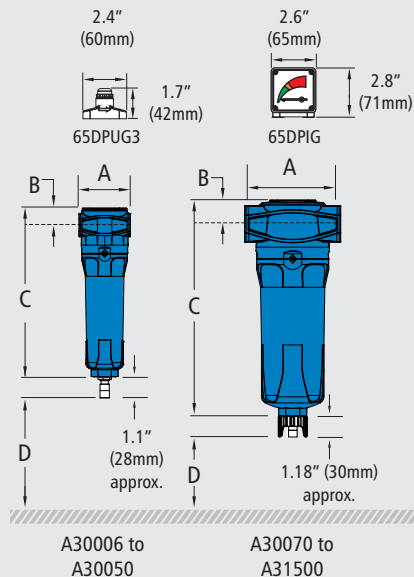

CRN

